

# The Journal of Borderland Research

## TABLE OF CONTENTS

HOW TO SEE VITAL RADIATION  
By Trevor James. . . . . 1 - 4

THE DWELLER ON THE THRESHOLD  
"THE SHADOW" of C.G. Jung. . . . . 5 - 8

INTO THE FOURTH DIMENSION IN 1953  
By M/Sgt Clarence Dargy. . . . . 9 - 14

THE TOPOLOGY OF A FOUR-DIMENSIONAL  
UNIVERSE, by F.B. Jueneman . . . . . 15 - 18

URI GELLER, CHALLENGE TO SCIENCE  
Part VI of a Review. . . . . 19 - 20

CLIPS, QUOTES & COMMENTS  
From a "Non-Arrogant Seeker", Haunted by  
a Durpu Elemental, Haunted by a Psycho-  
kinetic Dweller, St.Clair's Opus On Heal-  
ers Sold Out, Where Can I Sign Up?, More  
On "Eyes" and Occidental Meditation, Prac-  
tical Use of the "Eyes", The UKACO Device,  
The Lower Astral Plane, We Need It! Cur-  
tis Upton, Practical Mystic, Let Us Pick  
Up the Torch, Promising Results with UKACO,  
Telepathic Probing, The Phoenix Radio-  
clast, New Age Products Including Aura Gog-  
gles, Precise Mathematical Modelling of  
Thought, Women's Lib In Daytona Beach,  
Borderland Censorship Threatened, The  
Reincarnation of Peter Proud, The "Freedom  
Festival" at Tonopah, Literature. . 21 - 36

## THE JOURNAL OF BORDERLAND RESEARCH

BSRF No. 1 Published by Borderland Sciences Research Foundation, Inc., PO Box 548, Vista, California 92083 USA. Edited by the Director, Riley Mansard Crabb, Doctor of Metaphysics in the Society of St. Luke the Physician.

The Journal is published six issues a year with the assistance of the Associates, at the Director's home, 1103 Bobolink Drive, Vista. It is printed, 36 pages an issue. The Foundation was incorporated under California law, May 21, 1951, #254263, and has been in continuous existence since then. Address all correspondence to the PO Box. The Journal is included in the Foundation membership of \$7.50 a year. Single copies and back issues of the Journal are now \$1.50 each. If you don't care to join you may receive the Journal by donating \$7.50 a year or more to the Foundation. The Director's wife, Ms. Judith Crabb, is office manager and Secretary-Treasurer.

**PURPOSES OF BSRF:** This is non-profit organization of people who take an active interest in unusual happenings along the borderland between the visible and invisible worlds. In the words of the late Meade Layne, founder and director of BSRA from 1946 to 1959: "BSRA publications are scientific in approach but employ few technical expressions. They deal with significant phenomena which orthodox science cannot or will not investigate. For example: The Fortean falls of objects from the sky. Teleportation, Radiesthesia, PK effects, Underground Races, Mysterious Disappearances, Occult and Psychic Phenomena, Photography of the Invisible, Nature of the Ethers and the problem of the Aeroforms (Flying Saucers). In the year 1946 BSRA obtained an interpretation of the phenomena which since has come to be known as the Etheric or 4-D interpretation, and which has not been radically altered since that time. This continues to be the only explanation which makes good science, sound metaphysics and common sense."

The chief present concern of the Foundation is to make this kind of unusual information available as a public service at reasonable cost. Headquarters acts as a receiving, coordinating and distributing center. An important part of the Director's work is to give recognition, understanding and encouragement to people who are having unusual experiences of the borderland type and/or are conducting research in any of the above fields. For consultation on borderland problems or for Spiritual healing through prayer, write or phone 714-724-2043 for help or for an appointment. Donations and bequests toward Foundation research programs and expenses are welcome.

The 28-page list of BSRF publications is available from Headquarters for 50¢ in check, coins or stamps. This includes brochures on borderland subjects, tape recordings of Mr. Crabb's lectures and of members of the Inner Circle, talking through trance-medium Mark Probert. Write to BSRF, PO Box 548, Vista, California 92083 USA.

## HOW TO SEE VITAL RADIATION

By Trevor James  
From our June 1961 Round  
Robin Journal of Border-  
land Research

Many Associates have expressed interest in the technique mentioned by the writer in recent articles, of using pinacyanole bromide goggles for seeing the etheric double and vital radiation of a human being. Evidently, numbers of our Associates have had poor results with this material in the past, and it seems largely due to the use of inferior equipment and a lack of good guidance.

First, get the goggles from the Metaphysical Research Group, Archers Court, Hastings, Sussex, England. These people have a thoroughly reliable product, and in addition have invested considerable time and labor in pursuing all manner of research interesting to BSRAssociates. The goggles are ten bucks with the pinacyanole bromide filters, and come with a complete resume of the subject.

The writer's conversations with those who have tackled this project and failed indicate that all of them attempted too much too soon, saw nothing, and dashed their goggles down in disgust.

The primary aim of this experiment about to be outlined is not to enable the experimenter to see all the aura at once. The conviction should be firm in the mind that one is going to attempt to see the vital radiation, the luminous band of radiation that surrounds every normally healthy person. The vision is going to be confined to the areas immediately adjacent to the physical structure. The physical setting is extremely simple, yet there will be those who will attempt, for one reason or another, to avoid meeting these simple conditions. Don't do it! The proper method will ensure success; substitutes will produce something less.

Get a good, strong fluorescent light, preferably nothing less than three, three-foot tubes in a standard commercial fixture. Either lower this from the ceiling, or be able to stand on a chair or table so you can get your hands within 18 inches of the tubes. Try if possible to set up the arrangement so your eyes can be shielded from any direct rays from the fluorescent tubes. Ideally, the arrangement should look something like the following picture. Place a pure white surface under your hands. A towel, a sheet of white paper or white cloth will do the job.

STEP ONE: Either go outside in the sunlight with the goggles on



The Editor practicing Trevor's technique for seeing the Etheric Double, and for seeing 4-D UFOs. He uses economy "goggles" made up of a pair of sun glasses with deep blue gelatine filters over the lenses. After staring into a frosted light bulb for a minute (25 watt) he puts hands on white paper on desk, lighted by Circle-line fluorescent tube in desk lamp. After six months of steady practice, every day, he is beginning to understand the knack of seeing etheric matter or energy.

Photo by Judy Crabb

and spend approximately one minute gazing at the brightest surface available through the pinaculo bromide, OR, spend a minimum of one minute looking into a frosted, naked light bulb from a distance of a foot and a half.

Whichever way you choose, bring your will into play as you first stare through the goggles. If you are outdoors, seek to study with genuine intensity, some minor flaw or detail of the bright surface at which you are staring. If you are using the incandescent bulb, seek to see the filament of the bulb burning on the other side of the frosted finish. Peer penetratingly in either method and seek to arouse your faculty of sight fully.

STEP TWO: After a minimum of one minute adjusting the sight to the goggles, leave the goggles on and step immediately to your prepared position underneath the fluorescent tubes. Hold your hands in front of you, under the light and on top of your white, reflecting surface.

Now, resist the automatic tendency, induced by a lifetime of habit, to look at your fingers. You are not interested in looking at your fingers. You know they are there. Look past them, beyond them as it were, and into the space immediately surrounding them. Remember you are trying, in a certain sense, to see beyond the physical; so try and look beyond it.

If you do as has been suggested you will see that your hands are surrounded by pale, fine, luminous clouds of radiation that look like blue neon, though nowhere near as intense. Move your hands back and forth quickly in front of you. Observe how the radiation lags behind this movement, how the luminosity "jumps back" into its position around the hands. Your hands seemingly float in this fluidic emanation.

In the beginning you will probably find that your capacity to see the emanation will die away fairly rapidly, probably in two minutes or less. If you persist, you will find the ability to see this radiation increasing. If you are an Associate destined to be a real force in the New Age, you will keep on at it until the capacity to see this emanation is a permanent part of your sensory faculties. You will see it, in greater or lesser, degree, continuously, and often in full daylight at high noon, according to the background.

#### THE ETHERIC-DOUBLE

Perceptible along with the emanation right from the beginning is the human etheric double, or formative-force body as it has been referred to in modern times. This is seen as a luminous, pale grey duplicate of the physical body, standing out from the extremity of the physical structure by about 1/32nd of an inch all around it. The effect is like this:

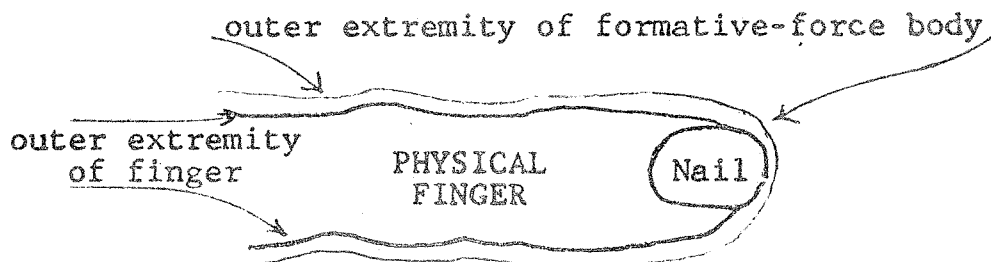

Inert mineral substances will be found to lack an etheric double. All living things, including plants, have this double and no biological theory which omits it can long endure in our time. The departure of the etheric double, which is death, results in the collapse and disintegration of the physical structure it underlies. At that time, the previously living body reverts to the purely mineral status that official science insists on ascribing to it in life.

The people who make the goggles outline a systematic method of use for them that will ultimately result in the perception of much more than has been described. The labors of Dr. Walter Kilner and Oscar Bagnall have been of great significance in the use and development of coal-tar dyes for this purpose. The writer freely acknowledges that the method outlined in this article, for the special and limited purpose described, was derived from the work done in England. The object was to find a quick method of perceiving the vital radiation by applying some lessons learned in the motion picture filming of the human aura. The writer has applied this method to well over 150 people, of all ages and levels of eyesight, without a single failure. Persons over 50 should spend about two minutes in the process of accustoming their vision to the goggles.

The writer is a firm advocate of Associates balancing their studies with doing. All of us cannot do experimental work, but things like this are within the reach of everyone. All the study in the world about the radiation from the human body will have only the aspects of dry intellectualism, until it is fused with the dynamics of doing and seeing. The effect upon the soul can be quite powerful, when the reality and the fact of this radiation is brought directly through perception into consciousness. The difference is that incalculable gulf between what you know and what you believe. Good luck.

\* \* \*

We made an aura-seeing setup at our Borderland Convention at Harmony Grove, California, July 4, 1961, complete with fluorescent lamp, white towel on table top, and 25-watt frosted bulb for staring at through the goggles. Dozens of conventioners tried it successfully, including your editor; but I was well aware that I was in the aura of the teacher, Trevor James. In fact he had his hand on my shoulder while I was seeing the pale, electric blue of the etheric double of my fingers. Later, at home, several tries produced nothing; so I put it aside. Now, 14 years later, after months of regular practice by myself, I am beginning to get flashes of the double close to the fingers, in spots, and also sometimes flaring out an inch or two.

Results might come faster if I had a pair of aura goggles but the main thing is to look through blue filters which apparently shift the sensitivity range of the eye toward the ultra-violet end of the spectrum. Once the sensitivity is built in through practice, the goggles or practice glasses can be put aside. Pinacyanole is expensive. I believe it can be bought through Eastman Kodak stores as a crystalline dye, but then it has to be liquified in alcohol and spread between two glass flats for seeing use. In our catalog (1972) of the Atlas Chemical Company, San Diego, California, Pinacyanole, Iodide Form is listed at \$5.78 a gram.

In Closed Class No. 7 with the Yada di Shi'ite, Aug. 27, 1967, the Yada spoke to the members of "magick in the hands. Under proper lighting conditions you can see the energy pouring from the fingertips. . . ." (Page 21 of the Transcript) I believe that the aura-seeing technique pictured and outlined above offers the "proper lighting conditions" suggested by the Yada.

This aura-seeing technique is one of several discussed and explained at length by Trevor James in his forthcoming book, "The Cosmic Pulse Of Life", expected to be out in paperback in the late fall of 1975. This updates his findings and beliefs on the Flying Saucer phenomenon since the publication of his "They Live In The Sky" in 1958.

## THE DWELLER ON THE THRESHOLD

### "THE SHADOW"

From "The Psychology of Jung"  
by Yolande Jacobi

Jacobi has done a neat job of assembling pertinent quotes and observations from the writings of the great Swiss psychologist, C.C. Jung, on the very real existence of what Jung called "The Shadow", and what we students of the Mysteries call The Dweller on the Threshold.

There is one important difference. Jung saw the Shadow as the creation of one lifetime only. We see the Dweller as the accumulation of misdeeds going back many lives.

To Jung the Shadow, or Dweller on the Threshold, was an archetypal symbol out of the mythology of the human race. Every human being becomes aware of It when he or she awakens to the totality of existence. Such an awakening can be a tremendous shock to the personality, as was suggested in the sudden death of Scotch actress Mary Ure in London early this year. It is the responsibility of the psychiatrist, and of the guru, to see to it that the awakening of his patient, or pupil, is within his capacity to cope with the frightening visions which come. Those who have boldly experimented with psychedelic drugs, and have had bad "trips", know what we mean. This has been the experience of many who are trying to awaken themselves "to the totality of existence" with biofeedback devices.

Jung

Out of his own tremendous clinical experience/found that awareness of the Shadow is the first stage in the process of awakening, of looking into our subconscious. This is our "other aspect", our "dark brother or sister", but it belongs inseparably to our totality because we have created it!

It was part of the genius of Jung to realize that the Shadow is absolutely essential to the full life! Without It there is no perspective, no depth to life. "The living form needs deep shadows to appear plastic," wrote Jung. "Without the Shadow the personality remains a flat illusion."

Swedish actress Liv Ullmann puts it another way but just as clearly. "I think we need our troubles and we are the better for them. The important thing is not to arrive but to be on your way." (Interviewed by Shana Alexander, "Newsweek" magazine, Feb. 17, 1975)



## ME AND MY SHADOW

Apparently Jung picked up the term, The Shadow, from studying the magick of Witch Doctors, Medicine Men, Shamans, Kahunas and other manipulators of earth forces. They all correctly saw the Dweller as inseparably attached to us, just like our shadow.

The Shadow or Dweller is a popular and frequently treated theme in Western literature. One reason is that the artist's choice of theme comes from his or her unconscious. The measure or the secret of the artist's success is their effectiveness in moving or obtaining a response from the unconscious of the public. One thinks immediately of the fabulous success of the Beatles, for instance, or of Elvis Presley here in the United States. Of course the unawakened public doesn't know nor care where this fascination comes from.

In literature we think of Francis "Shakespeare" Bacon's Caliban in "The Tempest", Dr. Faust and his Mephistopheles, Robert Louis Stevenson's Mr. Hyde. Oscar Wilde's Dorian Gray, Aldous Huxley's Grey Eminence, Chamisso's Peter Schlemihl, Mrs. Shelley's Frankenstein, Herman Hesse's Steppenwolf, Hoffmannsthal-Strauss's Frau ohne Schatten and, of course, Dracula.

The Roumanian vampire is an example of the Shadow or Dweller having obtained almost complete control of the personality. TV actress Elizabeth Montgomery portrayed the type very well earlier this year in "The Legend of Lizzie Borden", whose ax murder of her parents was the "crime of the century" a few generations ago.

Jung saw the Shadow as the "collective-human primordial", that part of our natures which we reject from moral or aesthetic grounds. We keep it in suppression -- most of the time -- because it stands in contradistinction to our conscious principles. It is never "lived out" or "faced". Yet It can be encountered either as an inner, symbolic figure, or as an outer, objective figure in one's life.

In dreams, the Shadow is the dreamer's mental and emotional traits in personified form. This is why dream interpretation has always been an important part of occult science, and dream control is the goal.

In waking life the Shadow can be any person who represents our opposite: an elder brother or sister, our best friend, a supervisor or teacher, or some mythical figure such as the Devil. The Shadow or Dweller could also appear objectively as a wild animal attacking us, or an elemental. Goethe portrayed It well in Mephisto, the sinister counterpart of Faust. Another great Dweller figure is Hagen in Wagner's "Twilight of the Gods".



## CREATIVITY IS STIFLED

The Shadow bars the way to the creative depths of the unconscious. It is that dark mass of experiences we have never admitted into our conscious life. This creates gloom and sterility of ideas. We try convulsively to hold ourselves on top without confessing our weaknesses to ourselves or to others.

A strong, recent, public example of this was President Nixon, tangled up in the Watergate mess. According to a recent article in the Los Angeles "Times" he still refuses to accept any responsibility for the felonies which destroyed him and his staff.

According to Jung and Jacobi a high spiritual and moral plane is not natural to us, but only an artificial scaffold held up by force and always in danger of collapsing under the slightest burden. The more we repress our Shadow, our Dweller, the more we become entangled in our neuroses, until it becomes an impassable barrier to effective conscious action.

Says Jung, "Everyone carries a Shadow and the less it is embodied in the individual's conscious life, the blacker and denser it becomes." And the greater the menace to our health. The person who constantly lies to himself and to others has warped crystals in his blood; thus the radiant energy coming from him -- if converted into music -- would be nothing but false notes and discords. Of course the "concert" orchestrated by the Shadow is not necessarily wholly bad, but only a display of inferior, unadapted, primitive qualities.

"A mere suppression of the Shadow is as little of a remedy as is beheading against a headache," says Jung. But when an inferiority is consciously faced up to one always has a chance to correct it. If it is isolated and repressed it can never be corrected -- in that life life at least, and may show up in the next one as an objective and obnoxious vice. Then the Shadow plays a fatal role in halting all psychic development.

## JUST AS I AM, WITHOUT ONE PLEA

Confronting one's Shadow or Dweller means becoming unsparingly critically conscious of one's own nature. Any Mystery School worthy of the name demands this of every disciple, every neophyte who joins up. "Man -- and Woman -- Know Thyself!" The early, "boot camp" training for everyone without exception is purification and self-discipline. This means not always blaming others for what happens to us. "I didn't do it; he did." Or, "It was the work of the Devil! He tempted me!"

Jung points out that this is why psycho-analysis doesn't succeed very often, because of the great resistance of the patient.

He or she cannot bear this darkness as belonging to himself or herself. The patient fears the structure of his or her conscious ego will collapse under the weight of such recognition. They will break off in the middle of an analysis and flee back to the shelter of their neurotic illusions. Any one of us can immediately think of a half dozen friends or relatives who are perfect examples of this kind of escapist behavior.

We questioned Dr. Leonard Chapman about that, in our book on Radionics. "When you bring up these deeper causes of disease in your patients, in the mind and the emotions, do you meet with resistance?"

"People wont accept them," replied Doc. "They wont accept them! A few will tolerate such suggestions. They will listen a little; but as for doing anything about them, no. Jesus said to the people of his day, 'Ye are not able to bear this.' He could tell them what the law was; but they wouldn't accept it; and we are in the same position today." (BSRF No. 33, "Radionics, the New Age Science of Healing", \$5.50)

#### THE WAR AGAINST SLEEP

But however bitter the cup may be it can be spared to no one, says Jung; without this there is no awakening to the totality of life, to living in the "House of self-collection".

Such an awakened person knows that whatever is wrong in the world is really in himself, or herself. By consciously learning to deal with the Shadow he or she is doing something real for the world.

"Such a person has succeeded in removing an infinitesimal part at least of the unsolved, gigantic social problems of our day." In writing this Jung only echoes the Word from the Mahatmas of the Himalayas, as quoted on page 11 of our July-August Journal: "Every time a son (or daughter) of man stands upon the Probationary Path Their work (the work of the Masters) is facilitated; for it means that one small stream of life-energy is directed into new channels and away from the old stream, which tends to vitalise and feed the evil form (of the collective Shadow or Dweller of mankind); and one more conscious assailant can be trained to cooperate in the work of destruction (of the Dweller).

"Every time an initiate is admitted to the Lodge degrees, it means that a new and powerful agent is available for the bringing down of force from the higher levels to aid in the work of disintegration. . . Here lies the clue to the present problem of evil, and to the vitality of the hold which the matter aspect has on the spiritual. . ." (The Master D.K. in Alice A. Bailey's "Treatise On Cosmic Fire")

## INTO THE FOURTH DIMENSION IN 1953

By Sgt Clarence Dargy  
A Radio Interview

**DARG:** I was stationed at an Air Force Base on Cape Cod (Massachusetts) in 1953, about June of 1953. We had one special F94C type aircraft. It was a two-seat fighter-interceptor with a pilot in front and a radar observer in the rear cockpit, both being covered by one canopy.

This aircraft was spotted out in an alert area, so whenever we had a UFO contact that aircraft would be immediately launched, with standby crews 24 hours a day. There was some sort of classified electronic gear aboard. Even I don't know what it was because any reference to the gear, in the resulting investigation, it would appear as the "secret so-and-so".

This particular night we had a UFO contact. This was just about at dark. The craft took off. The pilot's name was Suggs, Captain Suggs. The radar observer was a Lieutenant Robert Markhoff. According to Capt Suggs sworn statement -- he survived, incidentally -- they took off on the east-west runway heading directly west, toward Buzzard's Bay which is some 12 miles away.

The pilot said he pulled it off the runway -- this was on full after-burner and began his climb-out. At 1500 feet he had cleared the runway and was over the Base rifle range. At 1500 feet the aircraft went completely and utterly dead. Unlike an automobile which has only one central power source, if your battery fails -- in an automobile -- then you have nothing. Your engine quits, the lights go out, the radio and all these other things. An aircraft has a redundancy built into it, in that the different systems each have their own power sources, and the possibility of all of these power sources failing all at the same time are astronomical. The odds are -- I don't think you can even calculate them.

However, at 1500 feet he finds himself in this situation. His aircraft is completely dead. His engine has flamed out, navigation lights, instruments, radar. It took him a couple of seconds to realize what had happened. Immediately he cut the nose down to keep the aircraft from stalling because there was no possibility of accomplishing an

air start. A hard bailout. The bailout sequence in this aircraft is that when the commander gives the order to bail-out the radar observer operates the handle which blows the canopy off the aircraft. Then the radar observer himself ejects. The pilot then, on hearing this second explosion, is clear to eject. That's to keep them both from going out at the same time and colliding as they leave the aircraft; however, Capt Suggs said he did not have time to wait for the second explosion, because now the aircraft is in about a 75° down angle, toward the ground, 185 knots.

At about 600 feet he went out of the aircraft and he was about two to three seconds from impact. He ejected from the aircraft, his chute opened and acted like an air brake. It slowed him down and in one swing he was on the ground.

### BUT NOT THE F94C!

To make a long story short, the aircraft itself, somewhere between the time when he separated from that aircraft and the next two or three seconds, that aircraft literally vanished! It has never been found to this day.

ANCR: Now, Clarence Dargy, are you trying to tell us the airplane vanished? It was there one minute and the next, poof, it was gone?

DARG: It was gone.

ANCR: It was only two seconds from impact, I guess, and there was no impact on the ground?

DARG: There was no impact. No.

ANCR: Well what -- what happened after that?

DARG: Well -- that kicked off one of the most intensive searches we ever had on Cape Cod.

ANCR: And it happened in 1950 what?

DARG: 1953.

ANCR: In 1953. Now the pilot survived that crash or at least that incident. What were the relatives of the other man in the plane told? Were they told he just vanished?

DARG: Lt Markhoff's mother was a widow. She lived in Detroit. She was flown to the Cape immediately and spent the next three months there. Finally, in September, the search was called off. The search continued, by the way, all summer,

both on the ground, foot bodies, vehicles, helicopters. Any possible means of search, all possible means of search were used. Nothing was ever found; so her son was listed as missing, and presumed dead.

THE OFFICIAL WORD: LOST AT SEA

The public, by the way, was told that the aircraft had vanished at sea.

ANCR: The public was told that the aircraft had vanished at sea?

DARG: Yes.

ANCR: Uh, was there ever any attempt made to look in the sea to see if the aircraft was out there?

DARG: On the remote possibility that it might have gone into Buzzard's Bay, which was the direction it was headed in, the Navy brought up a dredge from Virginia. They dredged the entire Bay but they did not find any sign of the aircraft.

ANCR: Now, that runway where the plane went up and had a flame out and he lost his power, how, how far was that from the coastline?

DARG: 12 miles.

ANCR: Could that plane have glided out there 12 miles?

DARG: No possibility of that because when -- first of all the F94C is a very heavy fighter and interceptor and it has uh -- the gliding characteristics are extremely poor. When you chop the power on that you're just going one way and that's down.

The pilot's sworn statement said that he was in a 75° nose down attitude when he ejected. There is no way, even if they had someone in the airplane able then to pull the stick back, all the way back, they still -- the recovery time would have been too slow. They still would have impacted. The logic dictated that it should have impacted. It did not.

ANCR: Should have impacted but it did not.

DARG: It did not.

ANCR: How long did the Air Force -- were you directly involved in that investigation or search?

DARG: Yes, sir, I was, right from the beginning to the end.

ANCR: What was your position or title in that?

DARG: I was administrative assistant to the operations officer and we were the ones that interviewed the witnesses, got all the testimony, got all the aircraft records, the flight records, everything that could possibly come to bear and put them all together in the final report which was, oh, about 1½ inches to two inches thick.

ANCR: What was the final conclusion of that report, Mr. Dargy?

DARG: Simply: the aircraft could not be found. The findings were inconclusive. The case was never officially closed because there was a remote possibility that somehow, somewhere the wreckage of the aircraft might be found.

ANCR: This is "Operation UFO Search" and our conversation with Clarence Dargy will continue from station KTRH (Houston, Texas) in 60 seconds. (Cassette tape stopped for a commercial announcement, and picks up again with -- )

DARG: -- because there was a remote possibility that somehow, somewhere the wreckage of the aircraft might be found; but as of now it hasn't.

ANCR: Not even debris or even pieces of it anywhere, huh?

DARG: The only thing that was found was the canopy, and that was found on the rifle range right where the -- it was over the rifle range that it -- this happened.

ANCR: That ejected -- the canopy blew off and the pilot went out and about a second after that the remaining crew member of the plane and the plane just vanished.

DARG: Literally vanished, that's true.

ANCR: Did he -- could the pilot, after his ejection, could he have heard any sounds? Was he -- was it a cockpit ejection or open ejection or what?

DARG: Well, when you go out of an F94C the ejector seat -- it's a rocket-like device -- it just blasts you out of there. It blasts you out of the cockpit into a 185 mile-an-hour airstream and you're tumbling and whirling. Really you're not seeing or hearing anything. The world is a big, confused mess just about that time. The chute is opened automatically.

ANCR: I see. But if the plane had exploded before it hit the

ground, he, the pilot would have probably seen or heard something, wouldn't he?

DARG: He certainly would have, not only that, but he landed in the back yard of a house adjacent to the reservation and there were houses around that area and no one saw or heard anything.

ANCR: Were you ever able to turn up any other witness that saw the disabled craft or the flameout before it "vanished"?

DARG: None whatever.

ANCR: What about your people on the ground at the control tower. Were they watching that craft as it went off?

DARG: Well they would not have had it visually because it was dark. The rifle range was a considerable distance from the tower itself.

ANCR: I see. Well, the people on this kind of case -- I guess you have to admit this was a bizarre kind of case, and the fact that the plane just vanished like this was never mentioned to the public?

DARG: No, it never was.

ANCR: Do you know if it has been prior to this broadcast?

DARG: No, I don't think so. As a matter of fact I recited this very case two years ago -- that is publicly. We do have another gentleman in our organization who was president at that time. He's a retired Major intelligence officer. He said that the last time he had read that case it was highly classified.

ANCR: I would imagine so. Anything like this would be bound to fall into that secret, highly classified sort of thing. What about yourself, do you know if it is still classified?

DARG: I would imagine after all these years it might still be classified; however, I haven't the vaguest idea; I think that maybe people need to know some of these things.

ANCR: You're a former Air Force man. What was your rank when you retired?

DARG: I was a Master Sergeant.

ANCR: You were not an officer. There is a memo that travels around through UFO circles, or at least there is mention



of an Air Force regulation or a military regulation that all people who are involved in UFO investigations must sign under penalty of 10 years in prison and \$10,000 fine if they ever reveal certain of these classified things. Do you fall under that?

DARG: I have never seen that regulation. I have never even heard of that regulation. I have heard the rumors but there is -- to my knowledge -- no such regulation. (sound of background music indicating end of program)

ANCR: Clarence Dargy, former Air Force staff sergeant, who tells the story of the bizarre disappearance of an Air Force fighter plane, an F94C, back in 1953 over Cape Cod. What happened to it? What happened to the radar operator? Your guess is as good as mine. Join us again for Operation UFO Search at 1:35 on Saturdays or Thursday evenings for two hours of UFO information from KTRH in Houston, Texas.

\* \* \*

Our thanks to Associate Bill Dugan for sending us a Cassette tape of this radio interview back in April or May, 1975. Remember, this Cape Cod disappearance was eight years after the disappearance of the five Navy bombers in the Bermuda Triangle, and who knows how many other Navy, Air Force, Marine Corps and Coast Guard planes had flown into the 4th Dimension in that time? Certainly enough to force the military flatheads to admit that here was an enemy whose forces and functions were utterly beyond their comprehension! We had some pathetic letters about ten years ago from an Air Force widow. Her husband had vanished, along with the entire crew, and the search plane, which had been dispatched on some top secret mission.

There's small comfort in telling such an enquirer that her husband is probably alive and well in another dimension, or on another planet, building a new life and personality, and probably a new family -- because the old personality complex couldn't hold together crossing the abyss -- as suggested by Meade Layne and Ramon Natalli in Point 5 of "Nineteen Paragraphs" in CQC of the July-August Journal.

The apparently deliberate separation of Capt Suggs and Lt Markhoff in the Cape Cod case suggests another possibility, that radar observer Markhoff was an agent of the Forces that opened the portal into the 4th Dimension that night. His mission on earth was finished and he was returning to base for re-assignment. Probably the plane was wanted for the secret search gear aboard, for closer observation and analysis; for the construction of adequate counter measures. Remember also our information that selected Air Force personnel were allowed to view landed UFOs at Edwards Air Force Base, California in 1954.

## THE TOPOLOGY OF A FOUR-DIMENSIONAL UNIVERSE

Adapted from an article by Frederic B. Jueneman in "Industrial Research", April 1972

Scientific speculation on the probability of a Four-Space or Four-Dimensional universe has been accelerated by the disappearance of airplanes, ships and people. The shocking case in 1953, described by Sgt Clarence Dargy in the preceding article, is a good example of what physicists like Jueneman are up against. Let's look at some of his ideas.

"Let's begin with a little heresy and say that the Big Bang origin of our universe is untenable. To compound this felony let's also go further and say that the Steady-State theory also is full of holes.

"Now, we know that everything's here and came from somewhere, and, if tomorrow isn't cancelled due to lack of interest, the universe is going somewhere at a goodly rate. Or is it?

"Let's invoke some metaphysics, such as relativity, and take a look at the speed of light ( $c$ ). If an object approaches  $c$  velocity, and an outside observer has stop-action eyeballs, it will look foreshortened in the direction of travel."

Was this what happened to Capt Sugg's F94C over Cape Cod in June 1953? It was suddenly accelerated beyond the speed of light,  $c$ ? Nobody on the ground had "stop-action eyeballs" so to them the plane just disappeared from our 3-D continuum. If they had been practising Trevor James' aura-seeing technique with the goggles, they might have been able to follow the F94C through the Veil and see where it went!

"At light speed," continues Jueneman, "the object becomes two-dimensional to the observer and time seems to stop. And matter assumes its energy equivalent and will be virtually two-dimensional. The implications of this are that all photons and other electromagnetic phenomena are also two dimensional.

"If light-speed is ever to be exceeded the wave will have to be vectored toward a single dimensionality, so that at  $c^2$  it might be achieved (relative to our 3-D point of view, yes, but not relative to the point of view of the person riding the accelerating wave, who is still very much 3-D as far as he is concerned!) Hence the equation  $e=mc^2$  may refer to the energy equivalent at unidimensionality.

"To proceed beyond this to a zero, or point, dimensionality may be beyond the ability of today's relativity. (But not beyond the ability of today's occult science! The zero or end to which the physicist sees his 3-D continuum converging is the beginning of the next plane of consciousness or world which, for convenience we call 4-D.)

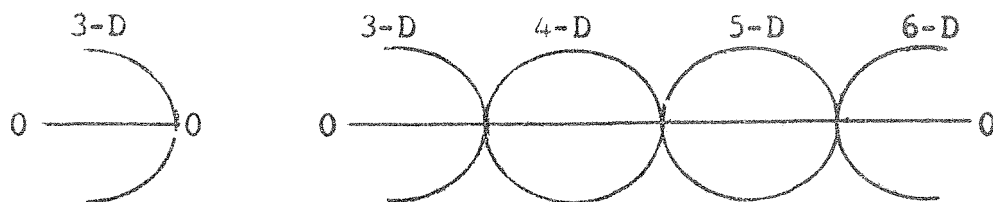

"The topology of such universes bemuses the imagination. At light velocity does time stand still? Beyond  $c$  up to  $c^2$ , which dimension vanishes and which remains? And would a universe existing in a point of zero dimension be but a cusp, a singularity into another parallel universe?

#### A CHANGE OF VIBRATION IS A CHANGE OF LOCATION

"Sitting here on space ship Earth one rightly might wonder how fast we are going. At the very limit of our telescopes, we see galaxies receding at over 40% of the velocity of light but to someone looking back at us we're the ones who apparently are moving out.

"For after a photon has traveled 3 or 4 gigayears past innumerable stars and gravitational fields, dust nebulae, and interstellar hydrogen it gets a bit tired and loses energy -- not speed -- energy. And in so doing there is the well-known red shift in the spectrum. If somebody is moving perhaps they aren't going quite so fast after all. Were everything to come to a dead stop, then tired blood-red light still would indicate movement.

"Let us now allow the stopped-motion universe to shrink, to collapse into the preterprimordial 'ylem' from whence the Big Bang is supposed to have originated."

A Cabalist would call the Big Bang the First Swirlings or Kether at the top of the Tree of Life. The "ylem" would be the Ain Soph Aur of Negative Existence, the black void of deep space from which the First Light emerges. But the Chaldean occultists from whom the Jews got their Cabala taught that there were two degrees of negativity beyond Ain Soph Aur: Ain Soph and Ain! Chaldean Cabalists attributed their wisdom to the Sons of Ilu, that is to Visitors and Teachers from 4-D space.

"With the entire universe crushed into a sphere about the size of our solar system the gravitational attraction would be so powerful that everything would be sucked into this black hole where not one solitary photon could escape.

"The theory that a singularity might exist, through which everything would vanish in a relativistic 'pip' is no more outlandish than the Big Bang idea. Maybe we were on the other side of the pip when it happened.

**INFINITE TIME = ABSTRACT SPIRIT**

"If motion defines the limits of dimensionality, where c approaches two dimensions, then complete motionlessness would describe a multi-dimensional universe with time as an infinite substituent (if it has any meaning at all)."

THE TREE OF LIFE

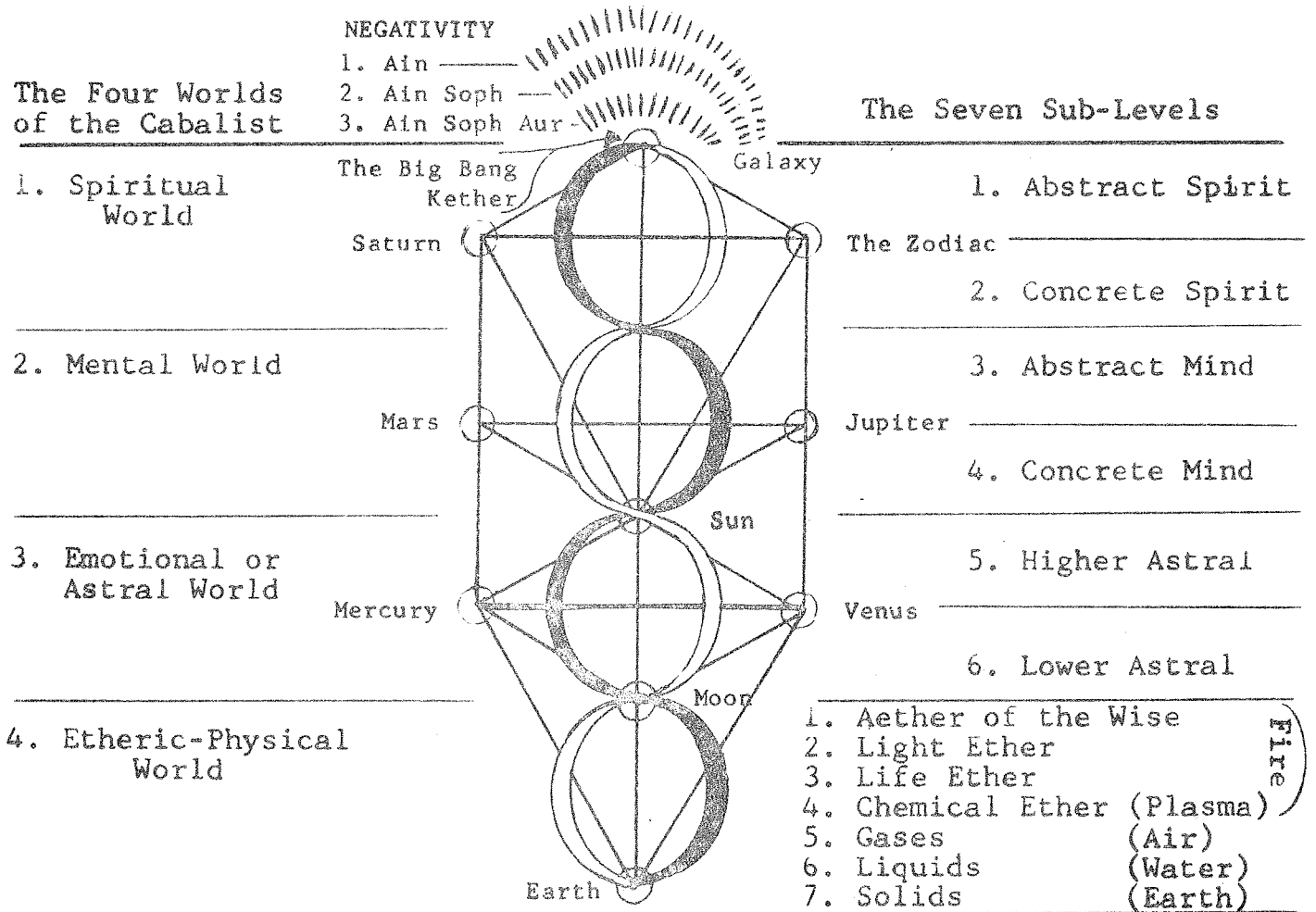

We would place Jueneman's "other side of the pip" at Ain Soph Aur on our Tree of Life, as well as his "infinite substituent". This blueprint of the universe is much, much older than parvenu Western science. Where did the Rabbis get their knowledge of the Zodiac and the First Swirlings of the Milky Way Galaxy? We say from

from Chaldean and Egyptian astronomers -- who were astrologers as well. In their view the solar system was a huge, step-down transformer with the raw, primeval power of the cosmos gradually reduced to the usable potencies we know here on earth. If the Chaldean telescopes weren't the equal of what we have today, we can attribute their impressive knowledge of star systems to their guides from outer space, the Sons of Ilu. Flying Saucers have been around for a long, long time.

#### THE "WHOOSH" OF LIGHT

"Also," continues Jueneman, "the ylem or any part of it is not restricted to a particular shape or conformation, as existence in this array would give very little meaning to shape. Therefore it would be a multidimensional topological horror in a shifting matrix with only time as a moving concept, racing backward and forward, with no finiteness.

"At some particular moment in time and space -- if these parameters existed -- the ylem reappeared in a dimensional array before it has completely disappeared from it. Then, and only then, was motion imparted to this protomatter (Binah in the Spiritual world, Saturn in the physical), and perhaps at that moment was the Loud Noise. Though it probably was something more like a Whoosh!

"Once the kinetics were initiated, the mass-energy fragment with a four-space characteristic phase-locked in as our universe, never to return until all its mass-energy recombines. No Big Bang as such need occur. And, to lend support to the holes in the Steady-State theory, as only a small fraction of all protomatter took part in the initial reaction, the remainder could from time to time inject a little into this continuum. However, if the phase relationship of our four-space excluded this then our universe is sealed in until entropic equilibrium is de-energized again.

"We might consider that our universe can shift, as an integral unit, through various dimensional levels, leaving something behind and picking something up as we go through, maintaining a steady state. A compromise which could combine the salient elements of both theories.

"Were we able to apply a conformation to matter so that it was motionless with respect to the universe (the Aether of the Wise on our Tree of Life will do), we could create a topology that might in theory cross over the dimensional boundaries and return in another part of our universe in almost zero time.

"It would require, of course, conditions merely hinted at in the most rigorous relativity principles -- and Einstein himself said that his views of the universe were like that of a person with extreme tunnel vision. . . ."

## URI GELLER, CHALLENGE TO SCIENCE AND TO METAPHYSICS

Part VI, of a Review of "Uri", by Dr. Andrija Puharich, Doubleday, New York, 1974, \$1.95

Pearl Harbor Day, Dec. 7, 1971 was notable for Dr. Puharich and Uri because the elemental nature of their contacts with the spectral Brahmin Nine was more obvious there in Tel Aviv. Telepathic and psychokinetic events had occurred, enough that Doc realized he was becoming more sensitive, without having to work for it.

The two met that evening at the apartment of Uri's girlfriend, Iris. They had no particular plans. Uri was hungry. Iris offered to hardboil three eggs for him and removed them, ice cold, from the refrigerator. When she turned to the eggs after putting a pan of water on the stove, she screamed and dropped them. They were boiling hot! Somebody was in a hurry to get them through Uri's supper and on their way to a rendezvous, with what?

Uri burned rubber driving away from Iris' apartment into the night, but he let Puharich direct them in random fashion through the outskirts of Tel Aviv. At 10 p.m. they were in a rough, open, bulldozed area where there was a scattering of new, unfinished, high-rise apartments. To Doc it looked like a dump, but he was moved to order Uri to stop the car and shut off the engine.

us  
"All three of/simultaneously heard a sound like one cricket continuously chirping," writes Doc.

They got out of his car and climbed a nearby embankment, looking in the direction of the chirping sound. There they saw "a blue stroboscopic light pulsing at about three flashes a second". They moved forward, through the open, muddy area, to within perhaps a hundred yards of the light and sound, when Uri stopped them.

"Only I am allowed to approach it."

But it was all right for Doc to try to get motion pictures of the pulsing light on color film. Uri moved off into the darkness. Iris shivered and cried, until Doc calmed her with an arm around her shoulders.

"We stood and watched the powerful blue light flashing; the cricket sound had ceased. Now we heard only the pock-pock-pock sound of the stroboscopic flash. I looked around. There was no one in sight in this vast dark field. Would Uri ever return?"

Yes, he did, in trance and after only a few minutes, his hands outstretched before him, palms up, as though carrying an open book; but the object laying on them turned out to be "the brass filler cartridge that had vanished from the inside of my Parker pen three days before! I quickly flashed a pocket light on it, and there I saw my code: #367299. I was overwhelmed by the meaning, the immense meaning, of this small object".

Puharich and Iris gradually brought Uri out of his sleep-walker state, walking him back to the car. "Andrija, please let's get away from here," said Uri and they drove a mile or so to another quiet spot. There Andrija got out his cassette recorder to record Geller's impressions of what had happened to him. Nothing spectacular. He walked toward the blue light. It was in front of a cypress tree. Then it was over him. He put out his hands. The pen cartridge materialized on them. His mind went blank until he saw Puharich and Iris on his return. He was gone four minutes.

Uri drove back into town looking for a coffee shop. In the back seat Puharich picked up his recorder again to make a few more observations on the night's experience. The forward and record buttons were jammed. "I turned on my pen light and looked at the recorder. The cassette tape on which I had recorded Uri's impressions of the experience in the field had vanished! I felt this was an object lesson to my doubting Thomas attitude."

For the scientist had been wondering if the pulsing blue light had been an hallucination? Perhaps, but the rematerialized pen cartridge and the dematerialized cassette tape certainly were not hallucinations! "But none of us could really accept the possibility that the blue light might be associated with a UFO."

After some snacks they drove Iris home and then Uri said that he had not told everything because "I don't want Iris to take all this seriously. I want her to forget it. . . But I tell you I know it is real. When I was out in that field, I realized for the first time in my life where my powers come from. Now I know for sure they are not my powers. Oh, I know that I have a little bit of telepathy and psychokinesis -- everybody has some. But making things vanish, and having things come back, and the red light in the sky in the Sinai, the blue light tonight, that is the power of some superior being. Maybe it is what man always thought of as God".

At Andrija's apartment Uri insisted he get out his Nizo movie camera and open it. He did so and found to his dismay that the Ekta 160 film cartridge had vanished. A sickening realization was beginning to come over the scientist "that I could never convince another human being of my experiences. The secret of Spectra was safe because they had leaked just enough information to convince me of their reality, but not enough for me to ever convince any other human being". (To be continued in the next Journal).



# CLIPS QUOTES & COMMENTS —

---

FROM A "NON-ARROGANT SEEKER"

"Clips, Quotes & Comments was most productive in Journal #3. I liked 'Mind Over Cancer' next best. Why not leave out Ray Palmer entirely? After all, he is entitled to his little mite. I still am waiting for you to clinch the truth as you review this and that revelation: Uri-Yoga-Unity etc. Instead you echo like a weak U.N. Since you 'know' so much why not realize a little? Evolve a technique.

"Just finished a powerful 'how-to' treatise you should read, 'Ultra-Psychonics' by Walter Delaney (Parker Pub., Nyack, N.Y.) Better than your 'four ways to freedom' because the non-arrogant seeker can apply it all successfully and overcome today's world. Why bother with the valley of the shadow? The Mandel Foundation of Box 6126, St. Petersburg, Fla. has cleaned up the low astral more than you seem to realize. Have you read the last few issues of EPOCH, the Mandel monthly organ? To hell with symptoms. Let's get with the whole truth and cut out the nonsense and the gossip. This 3/4 action group is deactivating the crystal and telepathing giants in the center of the earth. This is no supermarket. In Love."

C.H.W., Hemlock, New York

What makes you think that today's world wants to be overcome? Anyhow, I've got enough to do just trying to overcome my world! And if the Mandel Foundation has cleaned up the Low Astral, how come all this violent crime and other vice featured in the daily news? Seems to me that "telepathing giants" from the center of the earth are more active than they ever were, with or without crystals, as this next letter indicates.

HAUNTED BY A DURPU ELEMENTAL

"Two friends recommended that I get in touch with you immediately as I have been subjected to a very vicious psychic attack. It is being projected by Swami S \_\_\_\_\_ and Swami R \_\_\_\_\_ and is a Durpu elemental. I am really desperate as for one year I have sought help and done all I have been told to do, but haven't been able to break the force. My funds are limited as I have a mother 93 years of age in a hospital. Would you call me collect so I can ascertain what you can do to break this force and how we can get an appointment setup? There is a group of the White Brotherhood that meets at my home at Mt. Shasta. I could perhaps arrange a meeting for you there, plus you would have a comfortable home in which to stay. I am hanging on by faith alone."

M.A., Medford, Oregon

Thanks for the invitation to talk to a group at Shasta; we may take you up on it some time; but it isn't necessary for a face-to-face consultation. The guides and teachers of the Inner Circle who work with us can evaluate your situation immediately through your letter. In fact they may have inspired you to write to us! Because a physical plane contact is needed to help break up the obsession. The phone conversation with you revealed that you have a strong connection with these people because of the years of help and money you gave them -- until you had had enough! Without recognition or appreciation, or any real progress in your studies. If you had broken cleanly off, charged it all off to experience and set off in new directions, it isn't likely that this continuing trouble would have bothered you; but your resentment and bitterness caused you to continually brood over the injustice of it all -- and you probably criticised the leaders of this Ashram openly to the other devoted followers. This always invites malicious retaliation from teachers on the Left Hand Path; and they are far stronger than you because of training and a constant supply of mana or vitality drawn from their blindly devoted followers. This they use to constantly recharge the elementals sent to destroy you. You have to close the door to these attacks by stopping your negative thinking and feeling about the whole situation. Destroy the Aka Thread or karmic thread between you and these teachers by gathering up all their literature, correspondence and pictures and burning them in a cleansing ritual bonfire. Daily use of the Lesser Banishing Ritual of the Pentagram, explained and illustrated in our 50¢ brochure, "Retro Me", will continually break up any renewed connections they might try to make with you.

#### HAUNTED BY A PSYCHOKINETIC "DWELLER"

"I have a perplexing problem concerning disappearing objects, especially my I.D. cards, purses, etc. This also happens to my sons and to others if I associate with them. No one believes me except my husband because it happens to him! It would be worth my while for me to pay membership fees if someone there could help me prevent the phenomena from occurring, or if I could have sound advice."

G.L., Orland, California

My diagnosis, as a Doctor of Metaphysics, is that you have picked up an earth elemental or Gnome as an astral playmate; thus the psychokinetic phenomena going on spontaneously around you; but he, or it, wouldn't be attracted to you and carry on this way, like a pack-rat, unless there was some unconscious signal from you, or more properly from your Sin Body, your Dweller or Shadow.

Great deprivation early in this life might have developed a strong drive to "get what's mine", but now suppressed because you are too nice a person to indulge consciously in petty thievery;

and you now probably have enough abundance so that such thefts are not really necessary. Another possibility is that you -- or more correctly, your previous personality in another life -- was a petty thief -- say, a purse-snatcher in 17th Century London -- and the latent character trait shows up this way now. Other peoples' Dwellers show up as acute satyriasis, nymphomania, compulsive alcoholism, etc. If you could bring this psychic power to dematerialize physical objects under control, you could be a female Uri Geller, with a career on stage and TV.

It will take ritual magick to break up this subconscious drive and to cleanse yourself of the astro-etheric deprivations of the Gnome. By putting a protective circle around yourself and your possessions, night and morning, you can stop this for good; but you'll probably have to do it for some time, until the accumulated power is dissipated, broken up, scattered. This is the kind of purifying routine demanded of every student of metaphysics who joins a Lodge, Occult School, or Ashram. Your success in accomplishing the purification -- or redemption, to put it in Christian terms -- depends on your determination to rid yourself of the obsession. You created it; you must destroy it. The rituals in the enclosed "Retro Me" brochure have been of great help to many. I hope they are for you. Good luck.

#### ST.CLAIR'S OPUS ON HEALERS SOLD OUT

"I haven't been able to find David St. Clair's book on 'Psychic Healers' in the U.S. Would deeply appreciate if you could give me information regarding same. I am particularly interested in Rosita Rodriguez of Chicago and would appreciate her address. I understand she is a protegee of Tony Agpaoa, of Baguio in the Philippines. God bless him! In 1967 he saved me from death. All the doctors I saw gave me up. They couldn't do anything for me. I was reduced to 65 lbs. from 115 and there seemed no hope. My old problem has returned and I was hoping that Mme. Rodriguez could help me as I am unable to travel to the Philippines. Your publications are certainly above the usual and I really enjoy them."

J.M., Miami, Florida

"Psychic Healers" was published at \$8.95 in 1974 by Doubleday. Rosita Rodriguez's address, given in the back of the book is: 714 So. Scoville, Oak Park, Illinois 60304. Rev. Antonio C. Agpaoa's address and phone number are: Camp 7, Kennon Road, Box P, Baguio City, Philippines, phone 48-20.

Here's a case that proves it's easier to change the body than it is to change the mind! Obviously, this Associate is haunted by obsessive ideas which continually sap the vitality or mana, or block the flow of life forces from higher levels of consciousness. Daily meditation should reveal this to her and whether or not she wants to do anything about it herself.

## WHERE CAN I SIGN UP?

"Enclosed is money for Closed Class No. 1 with the Yada and for Seance Transcript BSRF 9-E, also a dollar donation for taking the time to answer one question about the teachings of the Yada di Shi'ite: Is there a Brotherhood with initiations, etc?"

W.H., Logan, Utah

Of course the Inner Circle is part of a Brotherhood with initiations, etc. You join it by studying and practicing the teachings, with assurance that you are under observation and inspiration, and that periodic evaluations of your progress in putting the teachings into practice are being made. You initiate yourself by working toward and achieving self-chosen goals, staying in each initiation until you are comfortable in it and can easily cope with the demands made upon you.

Take it for granted you have had contact with the Yada and/or other members of the Inner Circle in previous lives elsewhere on the planet, and that this present life is a continuation of work laid down long ago and completely unknown to you as personality, until you wake up to your Divinity and make a breakthrough to higher levels of consciousness where such permanent records are kept. Unless your Teachers have a physical plane school where you can go for training and physical initiations, you are on your own and will have to work your personal program out as well as you can. We don't know that the Inner Circle has a physical plane school anywhere; so your linkup will have to be telepathically. If you show yourself alert to the mental messages received and make a sincere effort to carry out the suggestions, more will be given. Eventually conscious contact with the Inner Plane Adepti -- as Dion Fortune calls them -- can be established; but you have to develop the necessary sensitivity from your side -- except in cases of real emergency.

To augment the instruction material which was channeled through Mark Probert, you will be guided to borrow or buy other occult material in print necessary to your continued spiritual growth. Good luck and keep the Light burning in Logan.

## MORE ON THE "EYES" OR CHAKRAS, OCCIDENTAL MEDITATION

"Will you please send me three copies of the Five Rites, 'The Eye of Revelation' by Peter Kelder? Enclosed is my check for \$6. Do you have a book that will explain more of the Vortexes stirred up by the Rites, with illustrations?"

F.E., Spokane, Washington

Yes, Volume I of our Lesson Series on the Cabala, "The Invisible Reality Behind Appearances", has material on the vortexes or chakras, with location along the spine, colors and chants appropriate

to our Western Mystery Tradition. It is interesting that Kelder derived the Rites from Tibet, but he used the term "eye" in his title to the brochure. "Eye" is the traditional Gnostic or Chaldean term for these vortexes in the etheric double. The Middle Pillar exercise of our Tradition is designed to cleanse and stimulate the Eyes along the spine. This is OM, Occidental Meditation. It's a great healing technique and is explained and illustrated in BSRF 24-A, 95 pages, 8½x11. . . . . \$3.25

#### PRACTICAL USE OF THE "EYES"

"A strange thing happened recently while experimenting with some banjo strings that kept popping up in my mind when lo! I remembered the John Keely of the 1870s! After going through back issues of your Journal I found the March-April 1973 number with the article 'The Mystery of John Keely', and along with it the address of John Howie of Natal, South Africa. The article refers to your having quite a number of excerpts of Mr. Howie and his delving into the Keely effect. Do you think he will accept correspondence along this line of thinking? My small lab is all primarily directed towards metaphysics and the hidden forces in our etheric plasma. Any other information you can pass along about Mr. Howie, the Keely Effect or other researchers in this field will be greatly appreciated."

Dr. Harry Lang, Searchlab, 1136 E. Brown St., Phoenix, Ariz. 85020

The article on Keely was written by Egerton Sykes of London. He is in touch with Mr. Howie, not us. I doubt if Sykes would have published Howie's address unless the latter wanted correspondence. H.P. Blavatsky, co-founder of the Theosophical Society, was a contemporary of John Keely. She wrote then, in "The Secret Doctrine", that Keely was a natural magician and I agree with her. He was born with his psychokinetic powers and, apparently ignorant of the principle of reincarnation, was unaware of the fact that he had spent thousands of hours in previous lives developing this power to send an invisible stream of etheric energy along a wire or a tube to run his engines. He augmented his psychic force with physical sound drawn from a violin string. When others bowed that string, at that same pitch, Keely was at a loss to explain their failure to activate the equipment.

If this is the Path you want to follow, you'll have to go through the same "boot camp" training Keely did, as a disciple in some Western "ashram" in Egypt, Chaldea, Greece, Palestine, as a Therapeut or Gnostic. To develop your "eyes" or force centers properly means a daily program of purification, occidental meditation and concentration of the kind laid out in our BSRF 24-A, Part I or Vol. I of our Cabalistic series (\$3.25). It means developing your visualizing powers to where a self-created thought-form is as objectively real to you as is your hand when held up before your eyes. You can start any time.

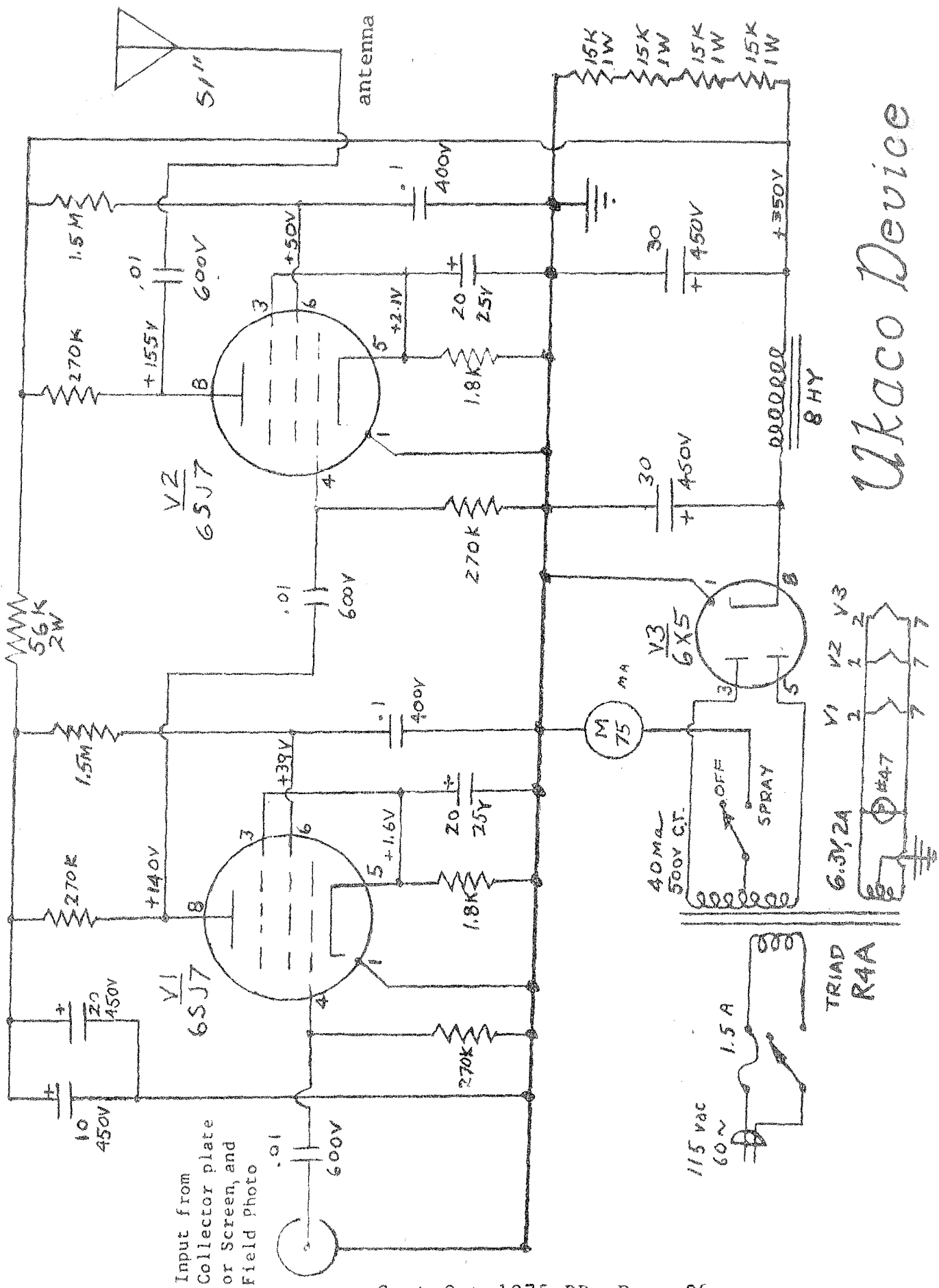

*Ukaco Device*

## THE LOWER ASTRAL PLANE? WE NEED IT!

"Hermes is the incarnation of Thot. Try to reach for Light so you will not have to depend on any one. I am sure Yada di Shi'ite will help you out of this lower Astral plane that you seem to want to stay in. Our group would like to get a copy of the UKACO Radionic schematic. In Our Father's Service."

H.M., Farmington, Michigan

Well, there's your schematic, on the preceding page; but if you build it and put it to use you are contradicting yourself! The UKACO Device uses Lower Astral Plane Forces to accomplish its results! These are the Forces that move physical matter -- including the destruction of millions of insects infesting a field of grain or vegetables. If you would be a practical mystic you have no choice but to deal with the demons or elementals of the Lower Astral World. If not, retire to some retreat in your northern woods and wring your hands helplessly over the plight of the world, and let it go to hell. Too many Tibetan lamas followed that Path and where are they now? Scattered to the winds. Remember your obligation under the Western Mystery Tradition, to bring the Life Force of the Logos, Kether on the Tree of Life, down to the physical world to redeem it.

BSRAssociate Curtis Upton was a practical mystic, so was Knuth. Their initials are the first two letters of UKACO. They invented this psycho-kinetic device for broadcast treatment of sick plants. Psychokinetics, action-at-a-distance, with an invisible, positive, Lower Astral force of the 7th Ray.

Fortune magazine did an article on UKACO in 1952. Meade Layne reviewed it briefly in Clips, Quotes & Comments. The University of Pennsylvania published bulletins on the successful use of this radionics or radiesthesia device, through its Farm Bureau, trying to encourage farmers to experiment with it. But the radionics treatment of plants was a major threat to the Oil and Chemical trusts, to their multi-million dollar annual sale of pesticides.

The artichoke growers of the Santa Cruz, California area were losing over 90% of their crop to insect pests in the early 1950s when Upton came along and persuaded one grower to give UKACO a try. It worked, of course, and the farmer harvested 90% of his crop! So, Upton had eager customers for his services the next growing season. But he was too successful. There was massive over-production of artichokes that year and the bottom fell out of the market. Nobody made any money but Upton.

A gleeful chemical salesman told his customers: "I warned you guys what would happen if you-all went for that new-fangled contraption!" And to make sure it wouldn't happen again the Oil and Chemical trust put their very effective lobby to work in Cali-



fornia's state capital, Sacramento. Now, in this state, it is illegal to do any electronic or Radionic broadcast treatment of plants except for research purposes. More than likely there are similar laws on the books of Texas and other agricultural states. This is visible, negative use of Lower Astral Forces to maintain monopoly and block progress.

#### LET US PICK UP THE TORCH

Now, with pollution of air, water, soil and food so much in the news, it is time to take up the torch laid down by Upton and Knuth at their passing years ago. Goodavage's articles on Radionics in the nationally distributed "Saga" magazine have helped renew interest in this Aquarian Age science. We do our bit with the publication of the Sam Gerald article in the July-August journal and a UKACO schematic in this, enough to give any dedicated borderland researcher a start. Both items have been added to the latest edition of our Radionics brochure, BSRF No. 33, \$5.50.

Note that the UKACO device is basically an amplifier, not a transmitter. The 6SJ7 tubes called for, sharp cutoff Pentodes, are generally used in amplifier circuits. These are the old, large tubes of the 1940s, as is the 6X5 rectifier. They may still be available but expensive. Acceptable miniature substitutes would probably be the 6X4 and 6EJ7s, and they're cheaper. At inflated 1975 prices cost of parts will probably be over \$40. The later, miniature tubes have a different internal structure; so be sure to consult a tube manual for proper connections. Triad's modern R 104A power transformer has the characteristics of the older, obsolete R4A. Good luck.

#### PROMISING RESULTS

"I have completed the UKACO unit and have started some broadcast tests with a garden opposite my apartment. It is too early to tell but it seems promising. Anyway, the worms have disappeared but that might just be accidental. I am also trying it on some plants in the apartment which have a lice problem. Should have some interesting news for you in another month on it. I've heard that a research organization in the States has made some very successful tests recently and is going ahead with a leasing scheme. Because of the potential of this machine to do both good and evil, I feel this should not be available indiscriminately; yet I am completely against monopoly control by one corporation.

"Many years ago I left the corporate world; for I found too many occasions when I had to say 'no'; for I have never subscribed to the motto that business is business. I have never been able to see any logic in that. Most of my life I have been working in fields that, though they were commercial, handled projects that were a benefit to others and especially to the developing world. I do not

believe, for instance, that what the world needs is more oil but a total change in outlook; so we develop an austerity based on a finite world with regard to our responsibility to future generations. We must get unhooked from consumer madness and the idea that giant size is beautiful!

"Do you know people in Europe and Australia with interest in this field? Would like to work with them and also get some UKACO units made there just to protect against patent attempts by one group. Like to have your thinking on this as it is through you I have managed to get this far."

A.P., Calgary, Canada

Yes, we have Associates in Australia, New Zealand, India, Sweden, Denmark, England, Hong Kong, the West Indies, Brazil and Portugal; so, with the mailing of this issue of the Journal -- and their receipt of it -- the UKACO device will have gone worldwide. We did the same thing in 1963 with Bob Beck's adaptation of the Lakhovsky Multi-Wave Oscillator; so I suppose thousands have been built and used for the benefit of mankind. Thus we fulfill our function, as a clearing house for unusual information. Several attempts have been made to destroy us, but the goodwill generated in the hearts and minds of those who have benefited from our service is a constant, living force which the Masters can use for our protection, at the Lower Astral level, where it is most effective -- our high-speed Freeway crash in 1967, for instance. The car was a total wreck but we walked away from that one, and our work continued without a break.

If any Associates write to get in touch with you, we'll be glad to forward their names and addresses. Your concern about the possibility that UKACO and Radionics can be used for evil, as well as good, has been foreseen by the Mahatmas of the Himalayas. We had the personal testimony to the late Dr. Ruth Drown, at her Hollywood lab in 1960, that she was under the guidance of the Master Morya. The Masters foresaw the terrible pollution that would result from widespread use of oil and chemical pesticides; the development of Radionics was one important solution to it. Naturally the Forces of Evil, through their agents in the commercial and industrial world, did their damndest to block it -- and succeeded to a great degree. Now these same Forces of Evil here in the United States are engaged in a desperate fight for survival, and are turning to Radionics and other psychic contraptions which they formerly despised. There is constant telepathic probing of the minds and hearts of our leaders from Russia, and the heads of certain government agencies in Washington know this. Mind Control is the name of the game now, and this heretofore secret aspect of Armageddon is coming out into the open. Let the secret agency giants of the two nations slug it out, toeto toe, and destroy each other in the process -- while we work and watch quietly on the side lines, preparing for the New Age.

THE PHOENIX RADIOCLAST

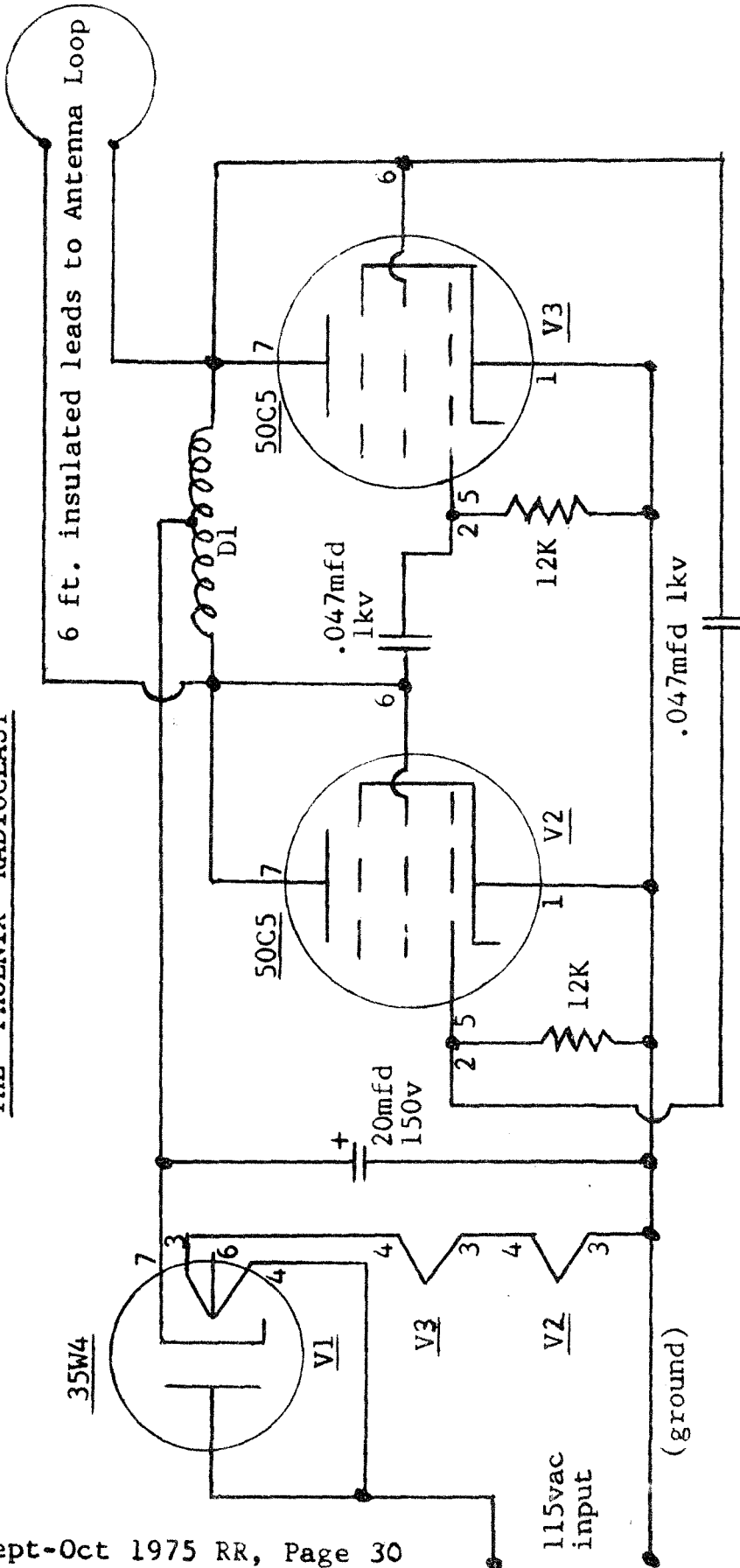

6 ft. insulated leads to Antenna Loop

Test Loop of #18 bare wire, 7 7/8" dia, connected to #47 bulb. Bulb should glow when TL is laid over Antenna loop.

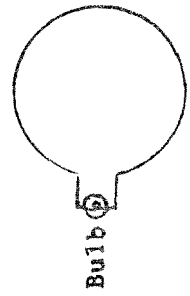

Antenna is a 7 5/8" loop of heavy insulated #14 copper wire. Lead wire and connections to Loop should be well insulated. D1 is a hand wound coil of hookup wire, 8 turns, 3/8" diameter, 3/4" long, center tapped.

Laid on any area of the body, the combined radio and TV waves tend to stimulate the flow of vital energy and blood there, relieving congestion and promoting new cell growth, and accelerating the elimination of waste matter. Radio research has found that tumors cannot survive in concentrated, pulsing magnetic fields of this kind.

## THAT INTERESTING PHOENIX RADIOCLAST

"Your interesting work was recently brought to my attention when I was given a couple of your Journals to read. Enclosed find 50¢ for your list of BSRF publications. Your May-June issue has a circuit for the Phoenix Radioclast. I've just finished building the unit. The multivibrator will not function until the cathodes of the 50C5's are connected to ground (pin 3, V2). No doubt this connection was accidentally left out. Incidentally, the maximum plate voltage for a 50C5 is listed as 150 volts. Given normal line voltage, a 100 ohm 1 watt resistor connected between pin 3 of the 35W4 and the leads normally connected to that pin, will cause the plate voltage to drop down to 150 volts and be more in line with the voltage value you selected for the filter capacitor.

"The unit is rich in harmonics and radiates well between 43 mc and 43.357 mc. My frequency counter is going crazy!

"I am interested in the UKACO circuit and any methods you know of to increase a person's ability at dowsing. If you wish a picture of my Radioclast, I would be pleased to send you one."

Stephen Gibson, Gibson Engineering, 547 N Beachwood Drive, Los Angeles, California 90004

The 43 to 43.357 megacycle range mentioned above by Mr. Gibson is the range of vibratory rates of the body's major organs discovered by Dr. Abrams in the early 1900s, and treated successfully by him with his Pathoclast.

The Lakhovsky MWO also puts out a broad range of frequencies which includes the 43 to 43.357 mc range; but it creates a lot of static with its open arc; and it also is more difficult to build with its hand-wound coil and wild, high-frequency voltages. The Phoenix Radioclast looks like a very acceptable substitute for the MWO.

We were given two schematics on the Phoenix. The first was published along with the article in the May-June Journal. The second schematic is reproduced on the opposite page. This one may be easier to work with and we've labeled the lower line for the ground connections.

Regular, conscientious practice with the "How To See Vital Radiation" technique described in the first article of this issue will help increase your overall sensitivity for Dowsing. Who knows, you might get to where you can see the radiant energy reflected off the surface of the underground stream up through the crust of the earth, as well as feel it with the Dowsing rod. Our Workshop exercises on OM (Occidental Meditation) will also help the Dowser tune up his mind, emotions and body for penetrating the Veil of the Fourth Dimension. These are in Part I of our Lesson Series on the Cabala, "The Invisible Reality Behind Appearances", BSRF 24-A, \$3.25

## NEW AGE PRODUCTS, INCLUDING AURA GOGGLES

"For several years now we have been selling the products recommended in the Edgar Cayce readings, also books and New Age products. I feel that some of your readers might be interested in these products, and especially in the appliances, such as the Violet Ray high frequency device, which can be converted easily to a Kirlean photography device or a Lakhovsky MWO. Literature is free on request from us at PO Box 444, Virginia Beach, VA 23458. Enclosed is literature for your files. I enjoy the Journal greatly."

Tom Johnson, The Heritage Store, Virginia Beach, Va.

Tom's literature list is timely in that he offers the English-made Aura Goggles mentioned in the lead article by Trevor James, "How To See Vital Radiation", \$16.50 a pair, postpaid. We're glad to see that the Scribner Solarama Board is still available at \$75. This emits clouds of healthful negative ions. One of the Cayce products that might be of special interest to the oldsters is the formula for revitalizing gray hair from the Cayce readings, #636-1. Actually it has been found to be a rejuvenating tonic generally in that it apparently stimulates the glands. It would take a pharmacist to blend the ingredients in the proper proportions: Syrup, Lactated Pepsin, Black Snake Root Extract, Essence of Wild Genseng, Atomidine, Extract of Liver and Grain Alcohol. 8oz, \$4.75.

## PRECISE MATHEMATICAL MODELLING OF THOUGHT

"Attached is an advance copy of a new appendix to my book, for your personal information. This appendix provides a schema to allow precise mathematical modelling of mind and thought. It also provides the basis from which a theory for a new class of phenomena, transfer phenomena, can be developed.

"Since Descartes, Western science has been developed with the rigorous assumption that there are only two classes of phenomena: (1) Subjective, the kind the psychologist classically studies, and (2) Objective, the kind that the physicist classically studies. Subjective phenomena are assumed to exist only if one thinks (of) them, while objective phenomena are assumed to exist whether or not one thinks (of) them. Specifically, Cartesian reasoning has rigorously excluded any third class of phenomena, i.e., transfer phenomena, whereby subjective phenomena could either partially or completely objectify (or partially or completely disappear! Such as the F94C airplane of Sgt Dargy in this issue. RHC).

"But parapsychology is faced with precisely such a third class of phenomena, whereby subjective mind affects or alters the objective world. This paper advances a scheme which includes all three classes of phenomena in a consistent manner. If valid, it will allow, I believe, a breakthrough of substantial magnitude to be made, and the rapid theoretical explanation of UFOs, parapsychology, ESP, pschotronics, psychokinesis and other forms of

noncausal phenomena."

Thomas E. Bearden, 30 Ripley Drive, Redstone Arsenal, AL 35808

From the above address it appears that Mr. Bearden may be an astro-physicist or engineer with the Army rocket facility at Redstone, Alabama; thus he is more than just a theoretician, but interested in practical applications of his borderland research. We'll try to get at least a summary of his Appendix in our next.

#### WOMEN'S LIB

Daytona Beach, Fla., (AP) July 20, 1975: "Six young women, apparently seeking to avenge a friend's rape, armed themselves with knives and attacked a Daytona Beach rapist, police said Saturday. 'They were revenging the rape, that's what they were doing.' Det. Don Walters said. John Dotson, 20, was reported in satisfactory condition in a hospital with multiple stab wounds. Police said a man had got into the car of a young Daytona Beach woman early Friday, held a razor to her neck and raped her. The woman was cut with the razor and required 16 to 20 stitches. The woman later swore out a warrant for Dotson's arrest but before officers could arrest him he was jumped by six women in the front yard of his home. Walters said the case would be turned over to the state attorney's office."

In view of the dismal record of Florida courts in trying and punishing rapists, is it surprising that the daughters of Isis are now and then taking justice into their own hands? For too long has the male-dominated legal system contributed to the degradation of women, and given Lower Astral plane forces free play.

#### BORDERLAND CENSORSHIP THREATENED

"I do hope you are interested in S1 (Senate 1) 'The Criminal Justice Reform Act of 1975'. This bill, if enacted by Congress, would put your Foundation out of business, as well as bookstores that carry data on UFOs or any other subject the government should choose to classify for whatever reason it saw fit. Check U. S. NEWS AND WORLD REPORT, June 30, 1975 pp. 34-35. Also CONGRESSIONAL RECORD June 25, 1975 pp. E-3521-E-3522, under remarks by Cong. Leggett of California. Maybe after the government disarms the public by taking the pens, as well as the guns, away, utopia can be ushered in. It appears to be one of the darkest hours in the history of this great country."

P.H., Whiting, Indiana

Yes, censorship bill S1 was originally the creation of President Nixon and his henchmen, after the criminal Watergate case was broken open by the enterprise of two Washington "Post" reporters, and before he was pardoned for his crimes by his appointee, President Ford. The intent of S1 is to make it illegal for the

news media to publicize any information on cases on trial before the courts. If this law had been on the books before Watergate the Nixon gang would still be running the country behind its protection, and all liberal publications like our Journal would, indeed, be out of business. Even the Los Angeles "Times", which did its damndest to get its hero, Adolf Nixon, into the White House, is now in deadly fear that President Ford will push this Nazi-type legacy of Nixon's through Congress. On Sept. 15th the "Times" published an editorial, "Putting Freedom Against the Wall", and pleaded with Congress to junk Senate Bill 1.

Law professor Vern Countryman of Harvard made this observation about S1: "The enactment of S1 would constitute an unparalleled disaster for the system of individual rights in the United States." The sinister provisions of this bill are buried in over 700 pages of legal obscurantism deliberately, to discourage any Senator or Congressman from really understanding what he is voting for, the legal basis for a police state. Reader Sidney Horton of the "Times" sent in this response to the editorial.

"S1 takes 753 pages to state the same basic premise of Hitler's Enabling Act of March 23, 1933. The 'Law for Removing the Distress of People and Reich' was condensed into five succinct paragraphs: all power resided in the Reich (federal) cabinet. Within this five-pound bill is the inclusion of Article 48 of the Weimar Constitution: permitting the chancellor in an emergency to govern by decree. S1's vague terms allow any appointed Cabinet member to govern by individual caprice. . . ."

Undoubtedly the dark angel from the Lower Astral Plane who inspired and is guiding this piece of legislation is Looeamong, the false Christ, just warming over the same evil ideas which inspired Hitler in the 1920s and 30s. If S1 does become law, we may as well head for the border, or perhaps activate one of our Doctor of Divinity degrees, rent a church here in Vista, and continue borderland research under the protective cloak of freedom of worship -- if indeed even that freedom will be allowed us by the powerful, reactionary forces which put Nixon on the throne in Washington in 1968.

### "THE REINCARNATION OF PETER PROUD"

Dr. L.O. Anderson has asked us to review this current movie Saturday night, Oct. 11, 1975 at his Anderson Research Center, 3960 Ingraham St., Los Angeles, Cal. 90005, phone 387-9164, 8 pm. The film is a powerful story because it has a lot of Lower Astral Plane vibes, too low for some people, no doubt; yet "Peter Proud" illustrates very well why Reincarnation should remain a closed book for the average person; the shock of past-life experiences would be too much for them. Today's problems are enough! We'll round out the talk with slide illustrations and a summary of the principles of rebirth as we understand them from our Cabalistic studies.



## THE FREEDOM FESTIVAL and UNDERSTANDING

Rev. Zelrun Karsleigh has invited us to lecture on "The Power, Wisdom and Love Rays, Their Use and Abuse by Mankind" at the Freedom Festival, International Cultural Center of Understanding, Tonopah, Arizona, Oct. 27, 28 and 29, 1975. The Festival follows two days of dedication ceremonies at Dan Fry's new Understanding Center at Tonopah. For those of you who enjoyed the annual Flying Saucer conventions at Giant Rock, California, here's a chance to get together again with enthusiasts and researchers in desert surroundings at Tonopah. George van Tassel will be one of the featured speakers. General subject categories for the three days will be:

First Day, Oct. 27th: ENERGY and the ENERGY CRISIS

Second Day, " 28th: FOOD, SUBSISTENCE and SURVIVAL

Third Day, " 29th: LOVE, LIFE, LIBERTY, HEALING and UNITY

Zelrun has invited speakers with expertise in each of the above three categories. The speakers will also give Workshops in their specialties: readings, healings, regressions, discussion forums and rap sessions on borderland subjects. For full information and registration write to the Rev. Zelrun Karsleigh, Universarium Foundation, Inc., 3620 SE 84th Ave., Portland, Ore. 97266, 503-775-2140.

For information on Fry's International Cultural Center and the dedication ceremonies for Oct. 25-26, write to Mary Ellen Curtis, Star Route, Box 588F, Tonopah, Ariz. 85354, phone 386-3832. The small community of Tonopah is on new Interstate 10 between Phoenix and Blythe, California.

## AND NOW THE MEDITATION AND STUDY CRUISE

Associate Elaine Peick is organizing a cruise for students of the Mysteries aboard the "Esmeralda" of the Orient Overseas Lines in April 1976. Ports of call will be from Los Angeles down the Pacific coast as far south as Corinto, Nicaragua, and including Acapulco, Mazatlan, etc. Elaine will conduct morning meditations, study sessions on occult science, and Workshops in healing and physical rehabilitation. The 22,000-ton "Esmeralda" is a combination passenger and freight liner with first class accommodations. For more details and information write to Mrs. Elaine Peick, 23852 Wardlow Circle, Laguna Nigel, Cal. 92677, phone (714) 495-0533.

## OM, OCCIDENTAL MEDITATION; BSRF 24-A

We remind our readers and Associates of our Workshop drills in relaxation, visualization, rhythmic breathing -- "five finger exercises" of the mind and heart necessary to increase your sense of well-being and energy, and to decrease tension, worry and anxiety. Daily use of these exercises lead to controlled ESP and to expansion of consciousness outside the physical. These are in Part I

of our "Invisible Reality Behind Appearances" series on the Cabala. The Ground Plan is the Tree of Life (Page 17 this issue) and the Western Mystery Tradition. 95 pages, 8½x11. . . . . \$3.25.

BSRF No. 2-P: FLYING SAUCERS AT EDWARDS AFB, 1954 -- A compilation of all BSRA documents about the secret landings of UFOs at the Air Force Base, Muroc Dry Lake, California high desert. We have reproduced Gerald Light's original letter to Meade Layne on the UFO landings, received April 16, 1954, Layne's Special Bulletin of April 16, and the lengthy interview about the Muroc-Edwards landings with Ramon Natalli and the Yada through Mark Probert the following day, April 17, 1954. The general import of their conversation was that the world faced almost certain destruction by total atomic warfare at that time UNLESS our leaders were shocked into full awareness of their suicidal course. A show of presence, and force, by the Guardian spaceships apparently was the method chosen. From our vantage of an undestroyed world in the early 1970s, it appears that the 1954 landings were successful; for it is quite likely that similar landings, and warnings, were made at secret military bases in China and Russia at the same time. This brochure also includes special report 10-C-53, transcript of a dialog between the Yada di Shi'ite and four physicists from the aero-space industry in San Diego at the time, about the "interior gravitational pull of the atom" and other undiscovered forces. Illustrated, 8½x11, 39 pages. . . . . \$2.25

BSRF 10-R: CLOSED CLASS NO. 7 With The YADA DI SHI'ITE, discussing such subjects as: Each New Generation Must Be Awakened Again, Any Approach Is Suitable, The High Priest Known As Billy Graham, The Teacher Must Talk With Two Tongues, Walk In Truth and Be Healed Yourself, Water The Neutralizer, Constant Abundance To Feed Others, In The Name of Amen the High Priest, etc. 31 pages. . . . . \$2.25

\* \* \*

# The JOURNAL of Borderland Research

Bulk Rate U.S. POSTAGE PAID Vista, Calif. Permit No. 42
---

A Publication of:

Borderland Sciences  
Research Foundation

PO Box 548, Vista,  
California 92083  
USA